

ASPIRAZIONE Ø 60mm

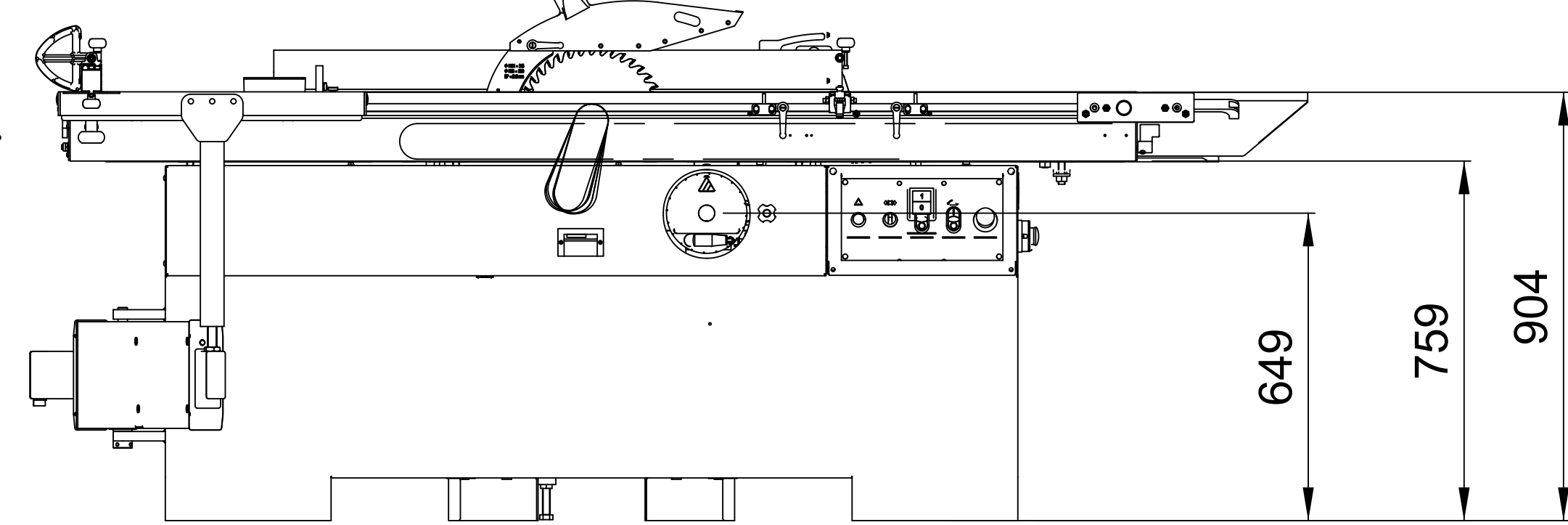

ASPIRAZIONE Ø 120mm

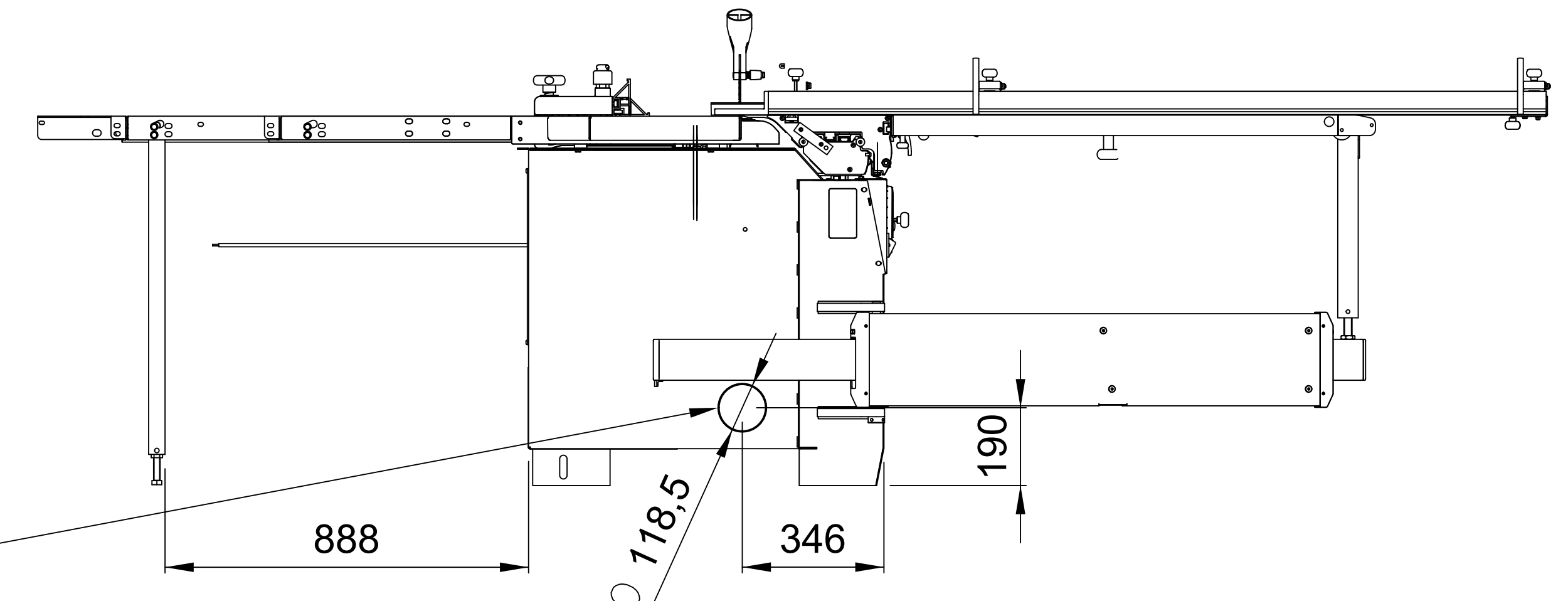

VERSIONE TAGLIO 1270mm

VERSIONE TAGLIO 900mm

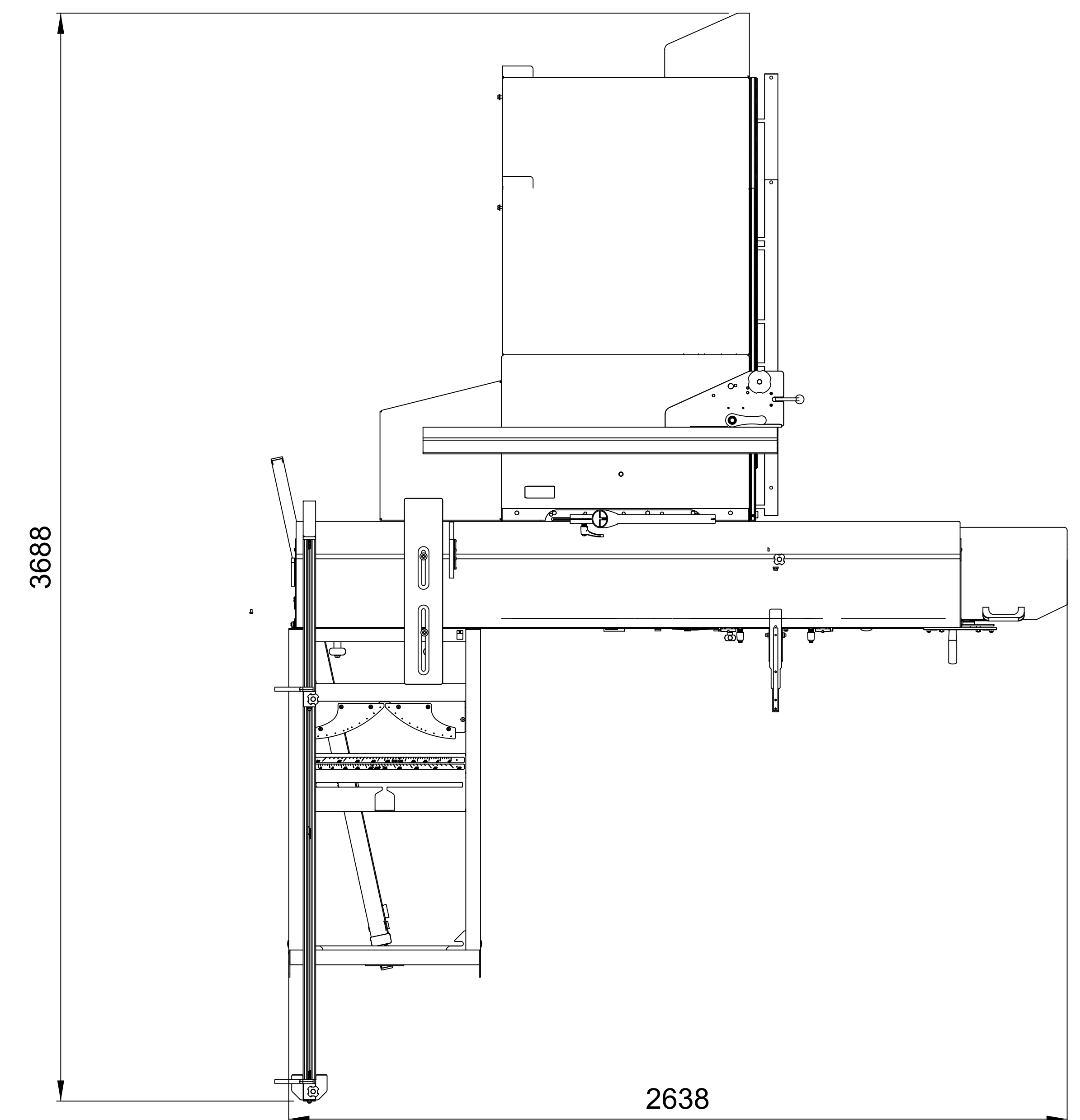
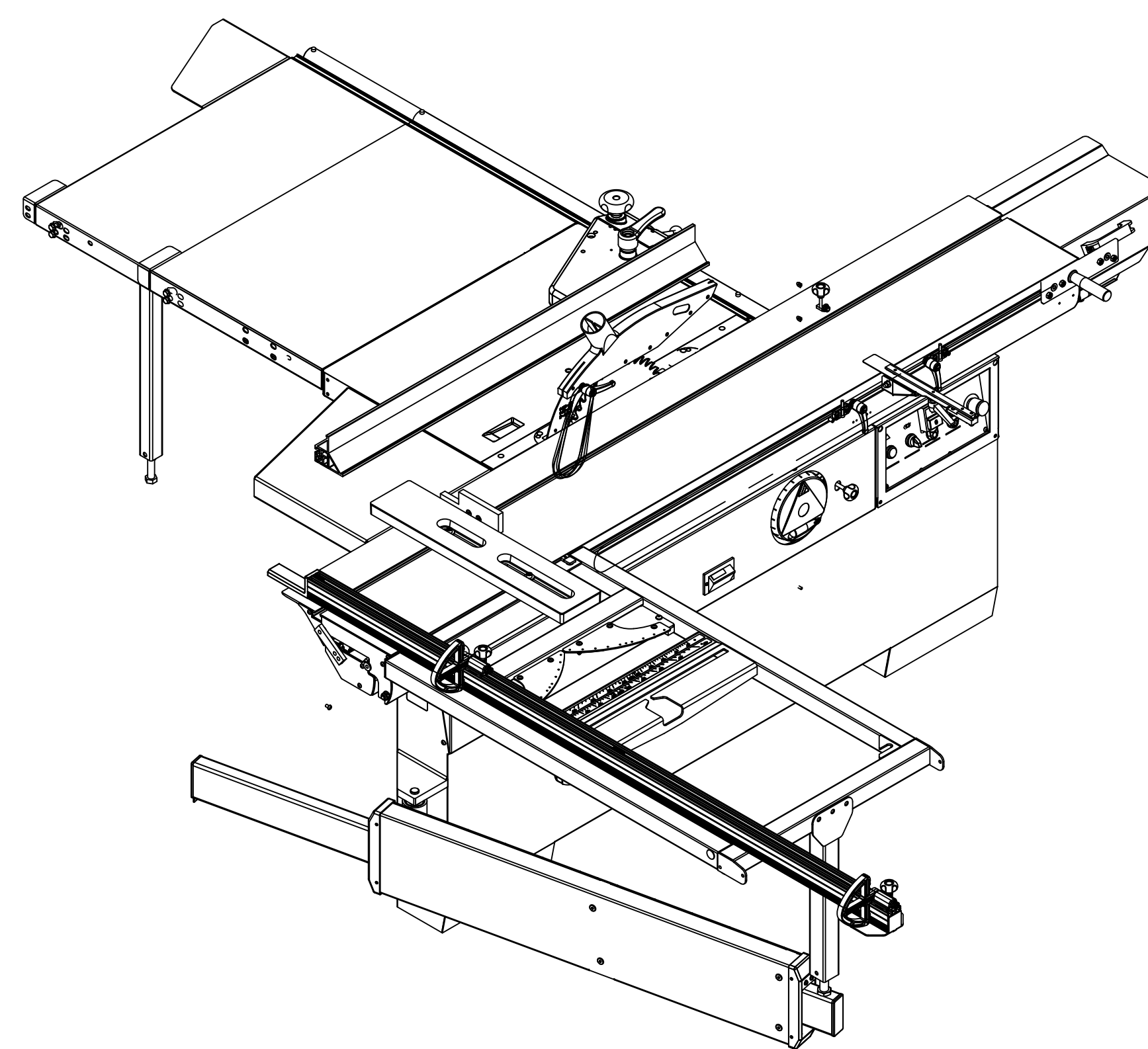
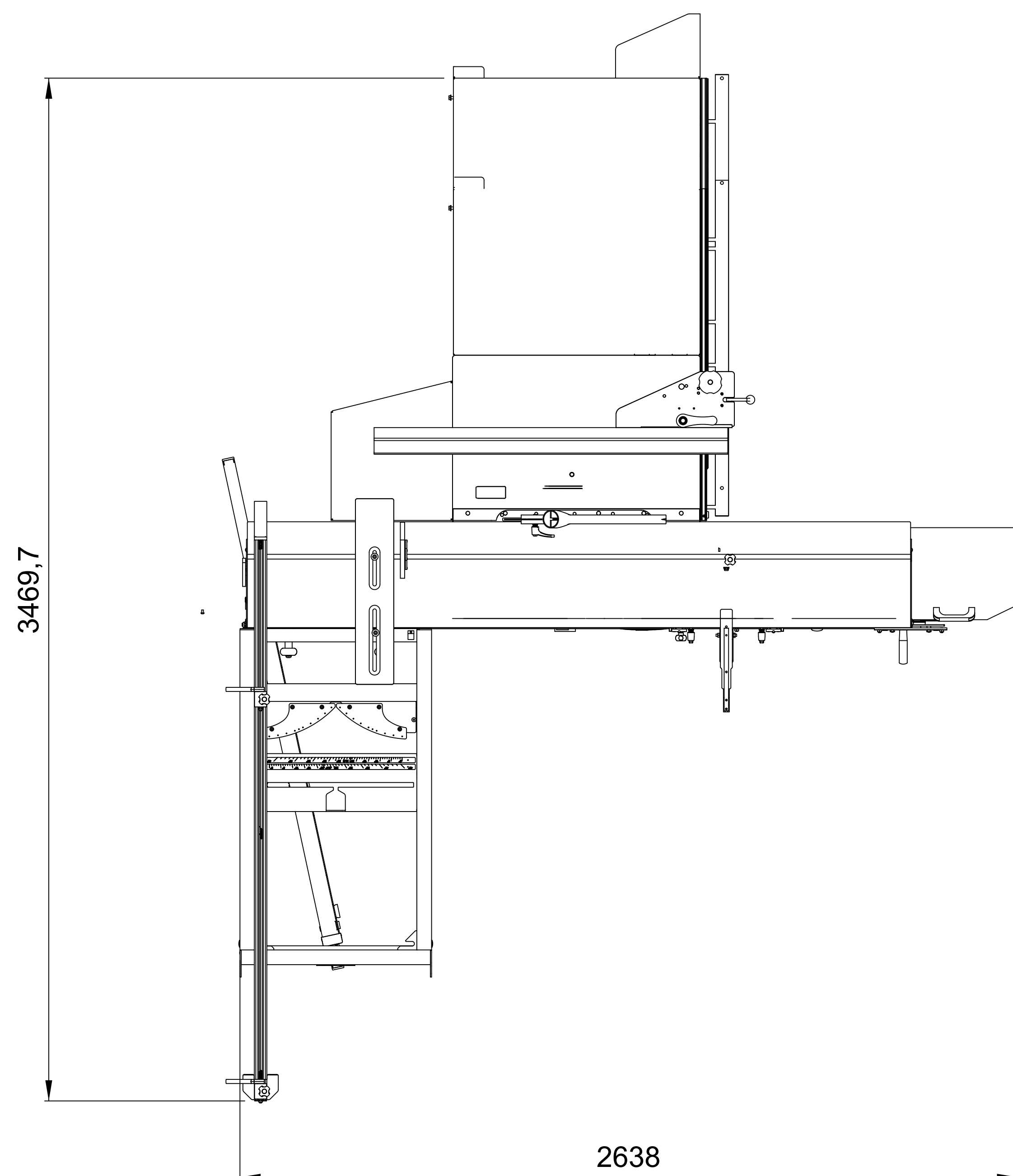

Rev	Data / Date	Firma / Signature	Descrizione ultima modifica / Last change description	N° Modifica / Change ID
			Caratteristiche tecniche non evidenziate secondo istruzione operativa SCM GROUP - IO 2310DTG Specifications not shown according to SCM GROUP operation instruction	
			Strutture saldate secondo specifica SCM / Welded according to SCM specific - ST2320TG Fusioni secondo specifica SCM / Mergers second SCM specific - ST2320TG	
			Quote senza indicazione di tolleranza, grado di precisione Shares without indication of tolerance, accuracy	
			Trattamento Superficiale / Surface Treatment ( SCM specific ST234DTG )	0
			Trattamento Termico / Heat Treatment ( SCM specific ST234DTG )	
			Peso grezzo/Raw weight (kg) 0	
			Smussi / chamfer	
			Massa / Mass (kg) 0	
			Materiali / Material ( SCM specific ST235DTG )	

		<b>SC 4 ELITE DISTINTA APERTA GENERALE</b>		Denominazione / Item Name
Scala / Scale	Codice / Item ID <b>33L0212996L</b>	Rev <b>01</b>	Status	Tav. N. di N. <b>3/1</b>

© RISERVIAMO A TITOLI DI LEGGE LA PROPRIETÀ DI QUESTO DISEGNO CON DIVIETO DI RENDERSILO COME AQUE NOTO A TERZI SENZA LA NOSTRA PREVENTIVA APPROVAZIONE. THIS DRAWING IS SCM PROPERTY. COPYRIGHTED MATERIAL. DISCLOSURE TO THIRD PARTIES WITHOUT OUR AUTHORIZATION IS EXPLICITLY FORBIDDEN.