

INTERRUTTORE GENERALE
MAIN SWITCH

285 ESTENSIONE CHIUSA / EXTENSION CLOSED
545 ESTENSIONE APERTA / EXTENSION OPEN

ASPIRAZIONE TRUCIOLI REFILATORE
ASPIRATION WOOD CHIPS TRIMMING UNIT

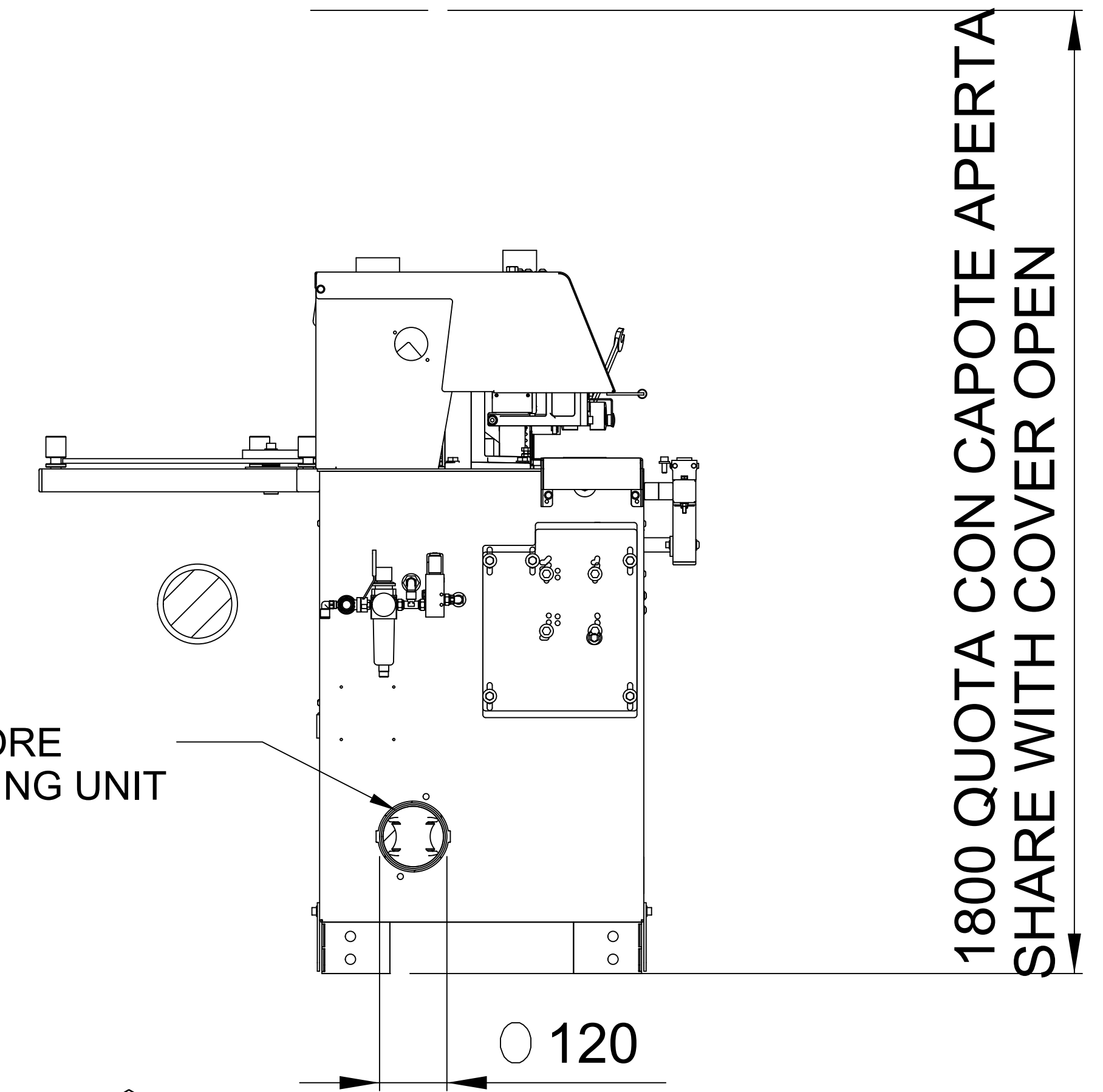

ASPIRAZIONE TRUCIOLI RETTIFICA
ASPIRATION WOOD CHIPS MILLING UNIT

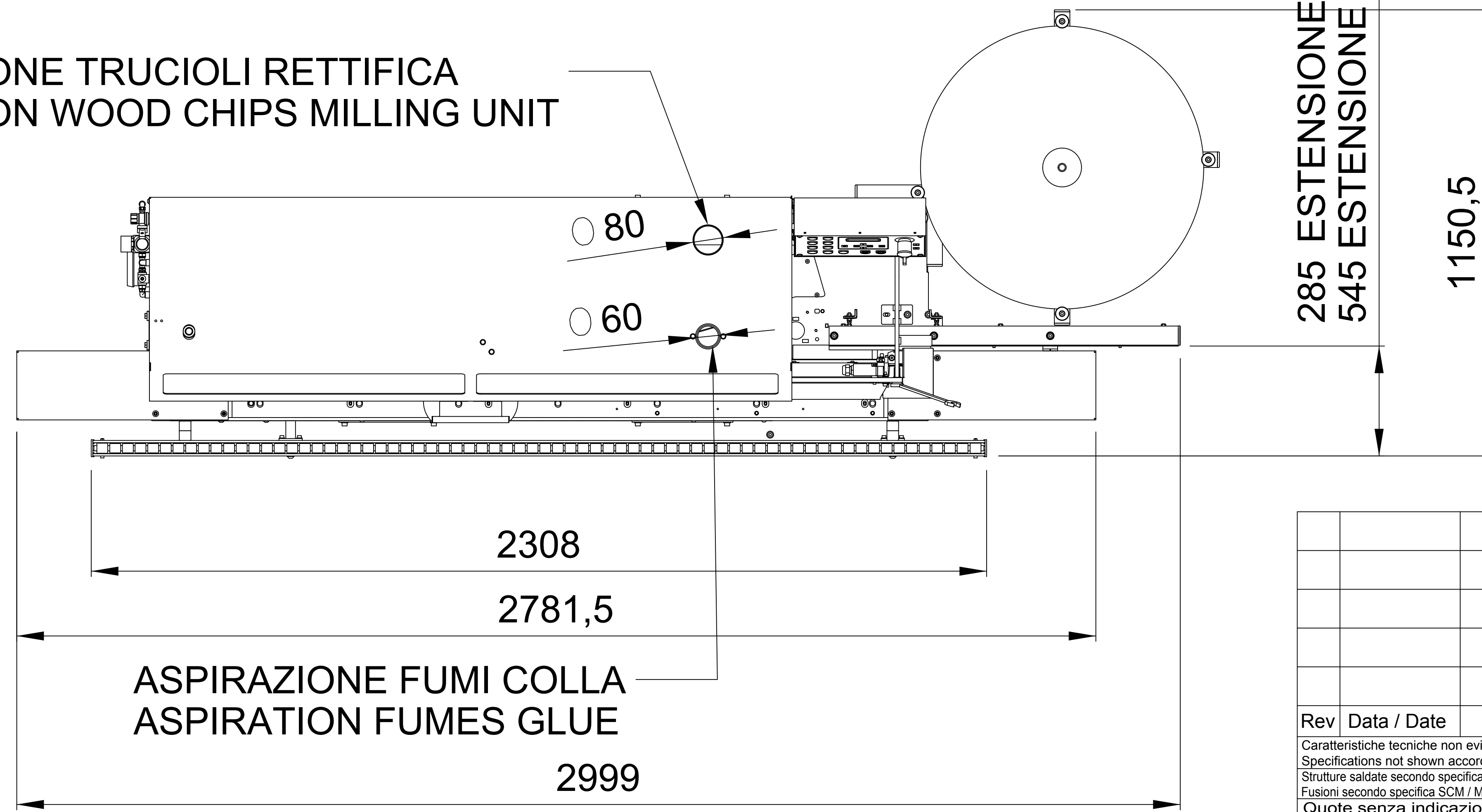

ASPIRAZIONE FUMI COLLA
ASPIRATION FUMES GLUE

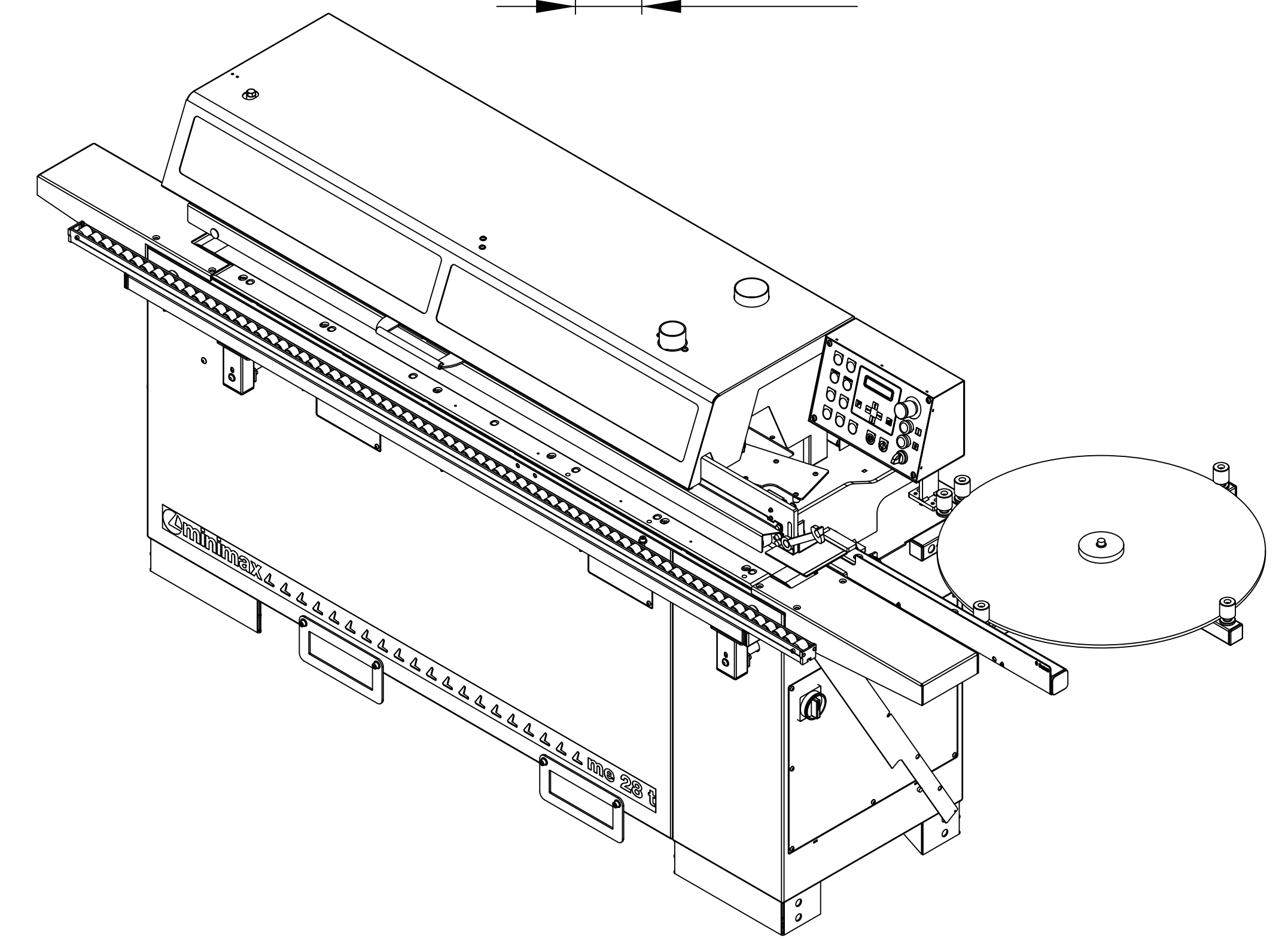

ALLACCIAMENTO ARIA COMPRESSA / AIR CONNECTION

ALLACCIAMENTO LINEA ELETTRICA / ELECTRICAL CONNECTION

ASPIRAZIONE / ASPIRATION:
V=20m/sec
Qtot=1330m³/h
ARIA COMPRESSA / AIR:
Pressione d'alimentazione / pressure network 8-10bar
Consumo d'aria / consuption air: ~600NL
POTENZA INSTALLATA / POWER:
In= 18 A
Pn= 5.5 Kw

| Rev | Data / Date | Firma / Signature | Descrizione ultima modifica / Last change description | N° Modifica / Change ID |
|---|-------------|-------------------|--|--|
| | | | | |
| Caratteristiche tecniche non evidenziate secondo istruzione operativa SCM GROUP : IO 23/1DTG Specifications not shown according to SCM GROUP operation instruction : IO 23/1DTG Strutture saldate secondo specifica SCM / Welded according to SCM specific : ST232DTG Fusioni secondo specifica SCM / Mergers second SCM specific : ST233DTG Quote senza indicazione di tolleranza, grado di precisione Shares without indication of tolerance, accuracy | | | Verniciatura / Painting (SCM specific ST231DTG) | Superficie / Surface (m ²) |
| SCM Specifica ST2310DTG | | | Treatment Superficiale / Surface Treatment (SCM specific ST234DTG) | |
| | | | Treatment Termico / Heat Treatment (SCM specific ST234DTG) | |
| Ultimo rilascio / Latest release Controllato / Checker Disegnato / Designed | | | Rugosita' / Roughness' Peso grezzo/Raw weight (kg) Massa / Mass (kg) | Ricavare da o Stato di fornitura / Based on or State of supply Materiale / Material (SCM specific ST235DTG) |
| Firma / Signature: M. Gabrielli Data / Date: 07/03/2016 | | | Smussi / chamfer CF3 0 36576521,49 | Vedi Nota |
| Denominazione / Item Name ME28 T DISTINTA APERTA GENERALE | | | Codice / Item ID 90L0365815B | Rev: 00 Status Tav. N. di N.: 1/1 |

scm@group

Scala / Scale
1:20

Codice / Item ID
90L0365815B

Rev
00

Status

Tav. N. di N.
1/1