

ASPIRAZIONE TRUCIOLI
ASPIRATION WOOD CHIPS

ASPIRAZIONE FUMI
ASPIRATION FUMES

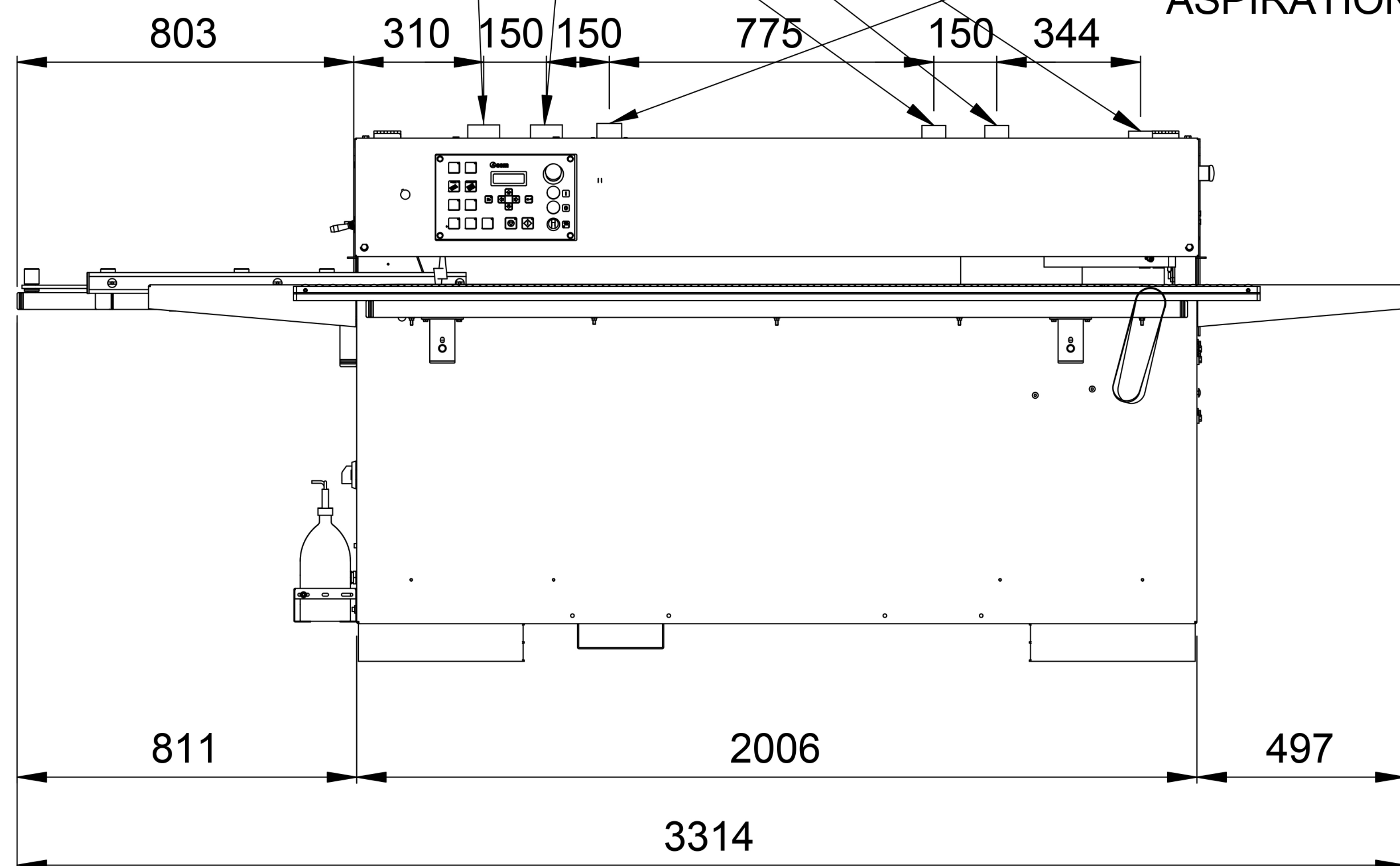

1700 QUOTA CON CAPOTE APERTA
SHARE WITH COVER OPEN

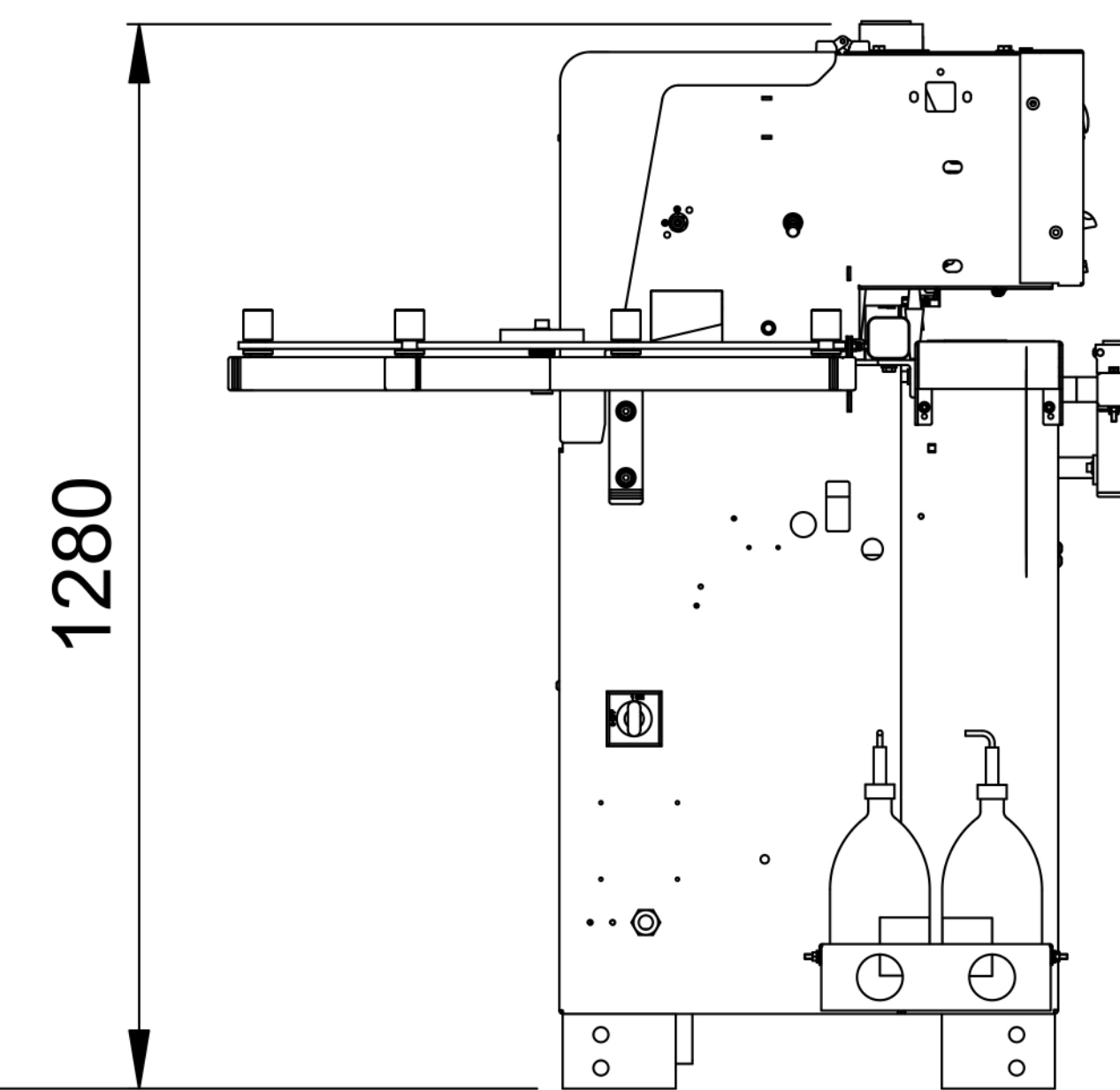

266 ESTENSIONE CHIUSA / EXTENSION CLOSED
615 ESTENSIONE APERTA / EXTENSION OPEN

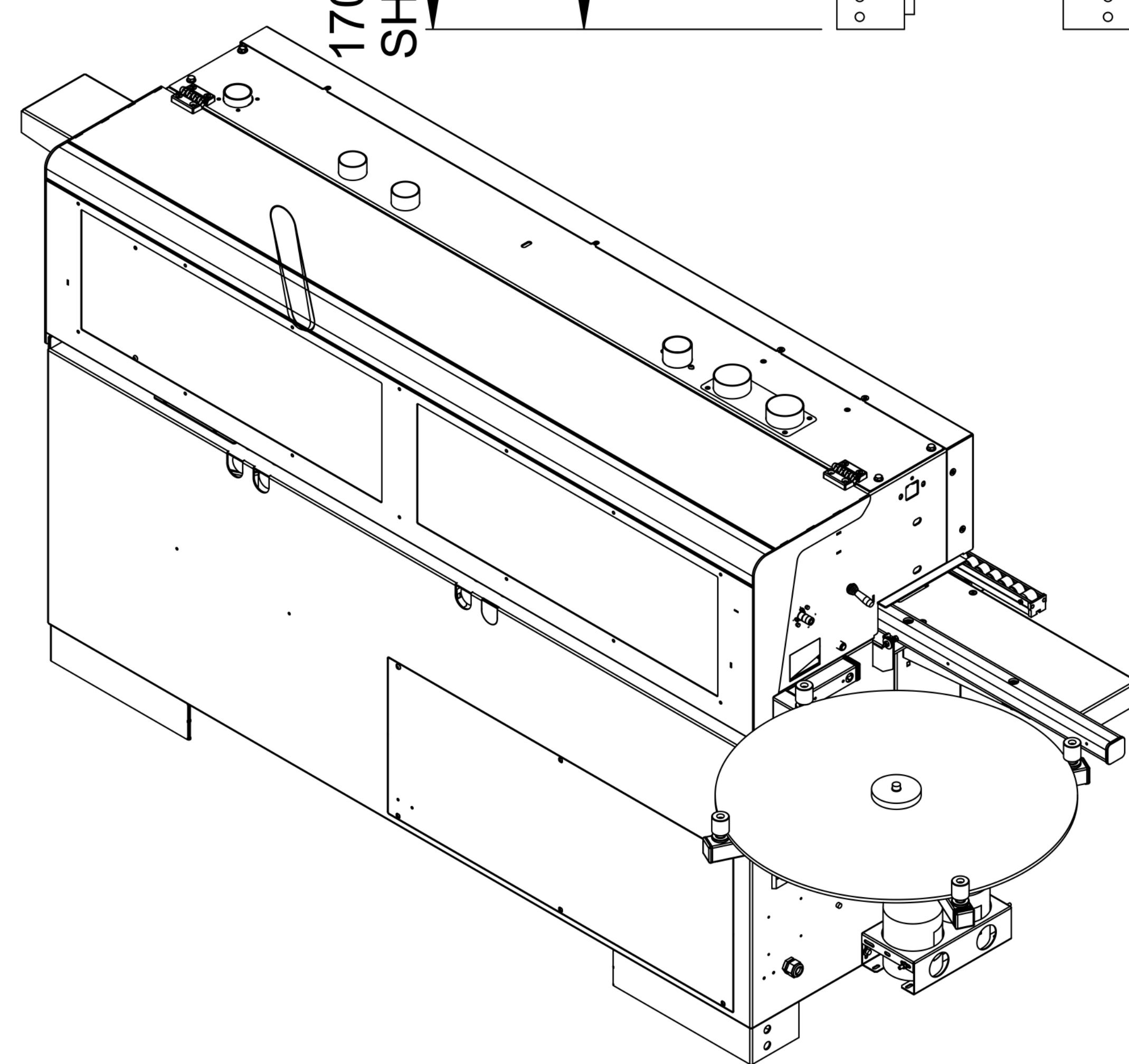
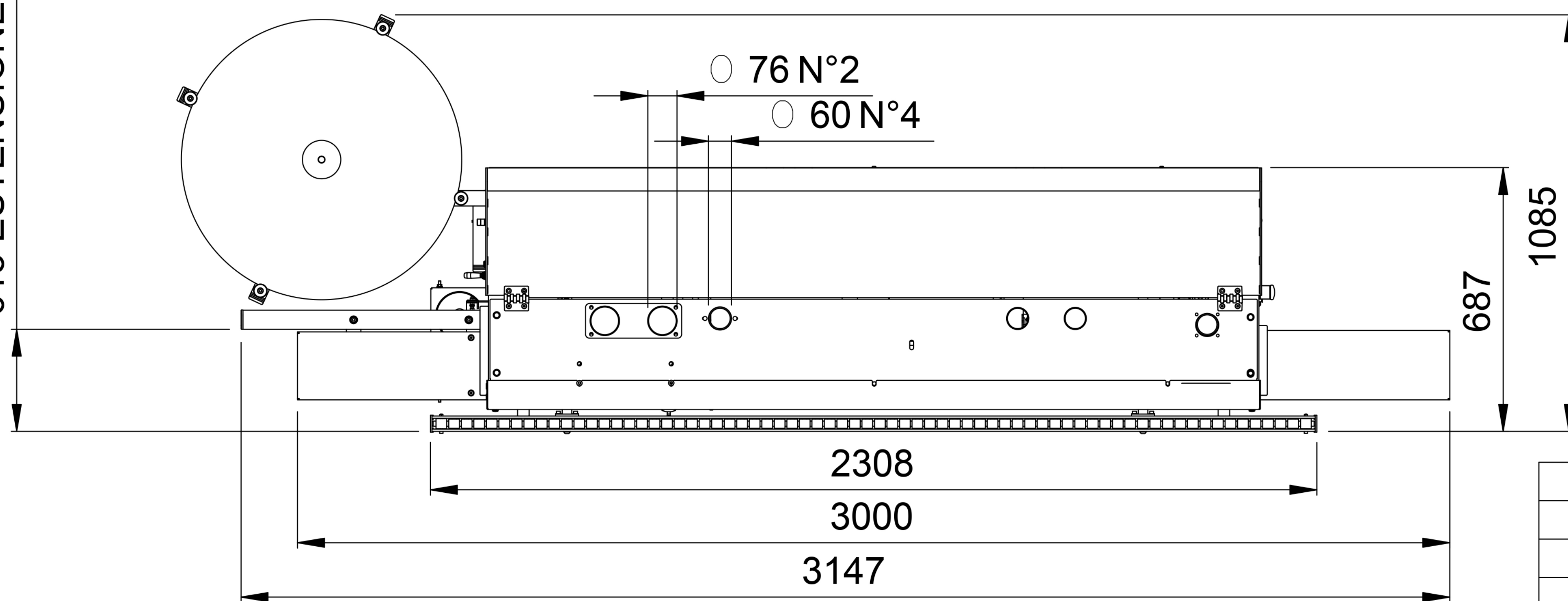

ASPIRAZIONE / ASPIRATION:

V=20m/sec
Qtot=1330m³/h

ARIA COMPRESSA / AIR:

Pressione d'alimentazione / pressure network 8-10bar
Consumo d'aria / consupcion air: ~600NL

POTENZA INSTALLATA / POWER:

In= 22A
Pn= 6.5Kw
Vn= 400V

ALLACCIAMENTO ARIA COMPRESSA / AIR CONNECTION

ALLACCIAMENTO LINEA ELETTRICA / ELECTRICAL CONNECTION

00					
Rev	Data / Date	Firma / Signature	Descrizione ultima modifica / Last change description	N° Modifica / Change ID	
Caratteristiche tecniche non evidenziate secondo istruzione operativa SCM GROUP : IO 23/1DTG Specifications not shown according to SCM GROUP operation instruction : IO 23/1DTG			Verniciatura / Painting (SCM specific ST231DTG)	Superficie / Surface (m²)	
Strutture saldate secondo specifica SCM / Welded according to SCM specific : ST232DTG			VER000		
Fusioni secondo specifica SCM / Mergers second SCM specific : ST233DTG			Trattamento Superficiate / Surface Treatment (SCM specifications ST234DTG)		
Quote senza indicazione di tolleranza, grado di precisione - SCM Specifica ST2310DTG Dimensions without indication of tolerance, accuracy			Trattamento Termico / Heat Treatment (SCM specifications ST234DTG)		
Ultimo rilascio Latest release			Rugosità' / Roughness'		
Controllato Checked by			CF3 0 0	Peso grezzo/Raw weight (kg)	Ricavare da o Stato di fornitura / Based on or State of supply
Disegnato Designed by	M.Gabrielli	01/09/2016	Smussi / chamfer	Massa / Mass (kg)	Materiale / Material (SCM specifications ST235DTG)
			Vedi Tabella		
			Denominazione / Item Name MINIMAX ME 35T		
			Scala / Scale 1:20	Codice / Item ID 90L0168696L	Rev 02
				Status	Tav. N. di N. 1/1